

Rexnord 1005 XLBP Series MatTop Chain

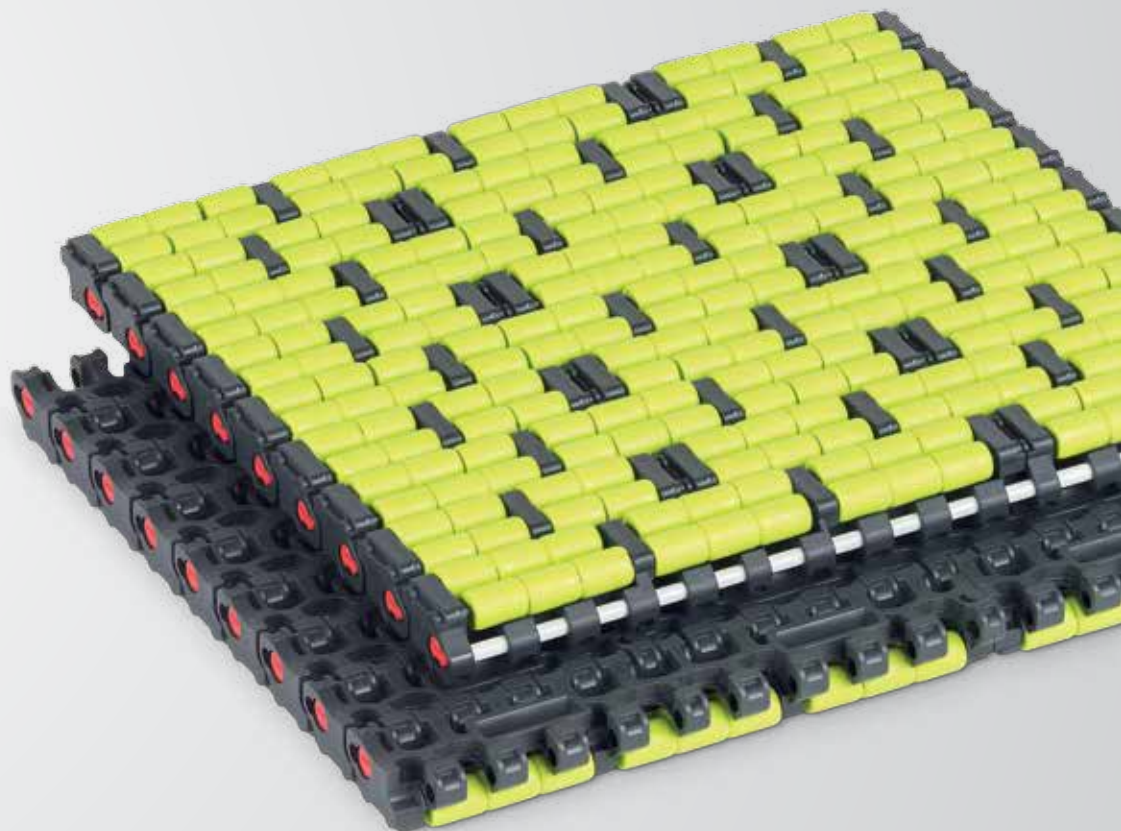



Rexnord 1005 XLBP Series MatTop Chain

Rexnord 1005 XLBP Series MatTop Chain Sets New Standard for Package Conveying

The Rexnord® 1005 XLBP Series MatTop® Chain is ideal for pack conveyors that require the lowest backline pressure. This design sets a new standard for the beverage industry with a range of safety, performance and energy features and benefits.

Why Choose Rexnord 1005 XLBP Series MatTop Chain?



Safety

- Small gaps between rollers, to ensure operator safety
- High visibility of rollers and moving parts which show that the machine is in operation
- Permanently fixed roller shafts improving environment safety
- Low noise level

Performance

- Backline pressure reduced by 30 percent to protect delicate packs
- Dynamic flow of packs over short head-to-tail transfers
- Low risk of rollers not rotating due to conveyor contamination

Energy

- Reduced headshaft tension provides low chain weight and reduced friction, translating into direct energy savings
- Wearstrips in ULF™ material are recommended

Comparative Modular LBP Chain Data

Gaps between rollers*

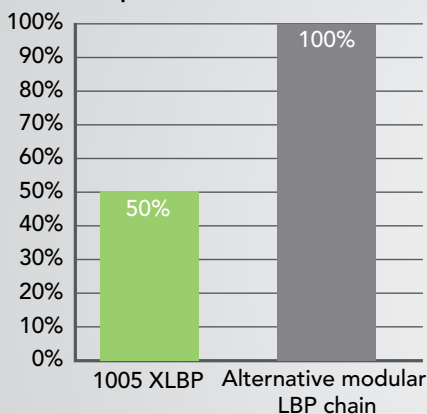

Backline pressure

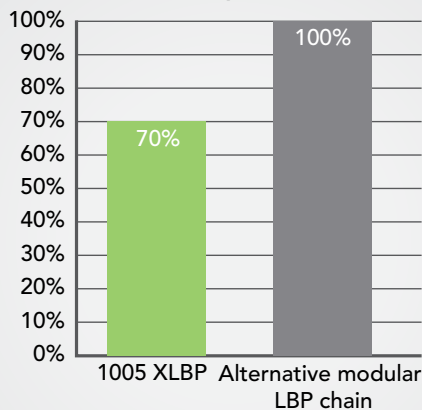

Headshaft tension

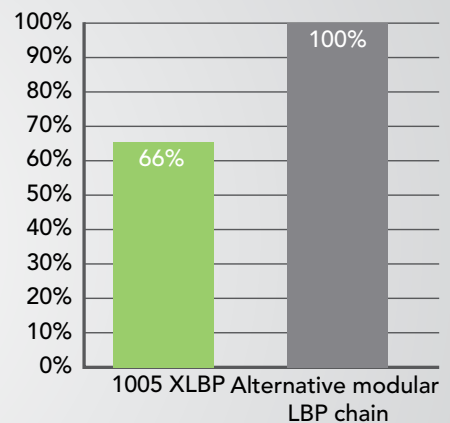

* When running over a sprocket with small diameter or nose-over with small diameter.

Based on following application configuration:

Conveyor length: 32.8 ft (10 m)
 Load: 6.7 lb/ft (10 kg/m)
 Accumulation: 100%
 Speed: 50 ft m/min (15 m/min)

Based on following application configuration:

Conveyor length: 32.8 ft (10 m)
 Load: 6.7 lb/ft (10 kg/m)
 Accumulation: 100%
 Speed: 50 ft m/min (15 m/min)



Rexnord 1005 XLBP Series MatTop Chain features and benefits

Energy-saving

Reduces energy consumption of the drive motor with 25 percent lower chain weight and easy rotation of the rollers ensuring minimal backline pressure

Low backline pressure

Easy rotation of the rollers to ensure 30 percent lower pressure on the packs during accumulation

Twist-lock pin retention clips

Secure the pins in the chain for easy and quick installation

High visibility

LBP rollers in bright lime green color enhances visibility of the chain and chain movement

Radius in modules

Minimizes chordal action and kick-up at transfers with small diameter nose-overs or sprockets

Safe design

Lower position of the rollers on the chain reduces gaps between the rollers of the chain at conveyor transfers

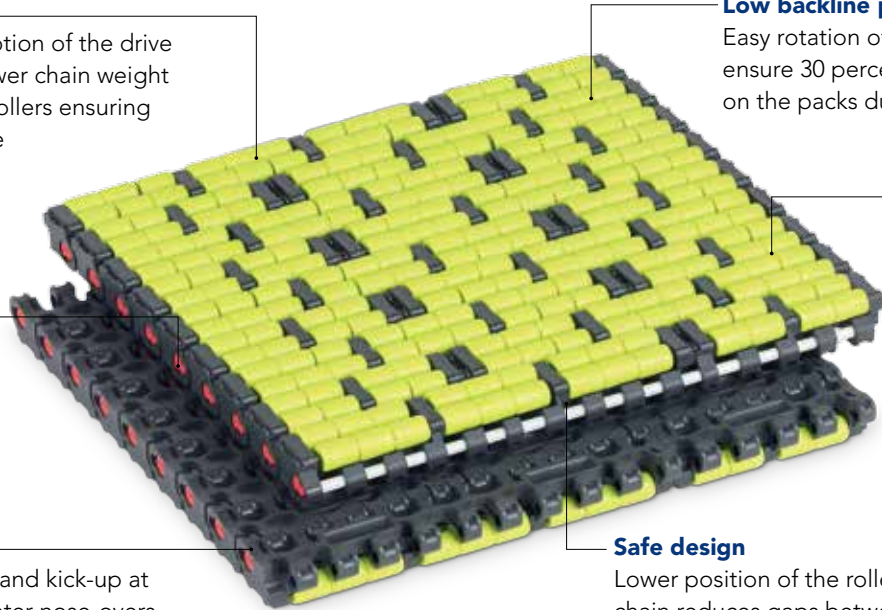

Chain Features

- **Chain pitch:** 1.00 inch (25.4 millimeters)
- **Thickness:** 0.79 inches (20.0 millimeters)
- **Minimum back-flex radius:** 4.72 inches (120.0 millimeters)
- **Chain material:** XLA, low-friction acetal
- **Standard pin material:** Polyester
- **Direction of chain travel:** Bi-directional
- **Nose-over diameter:** 1.96 inches (50 millimeters)

Rexnord 1005 XLBP Series MatTop Chain

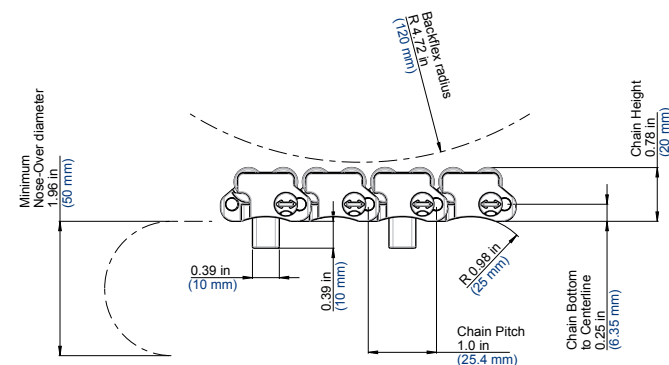

Transfer setup with nose-bars

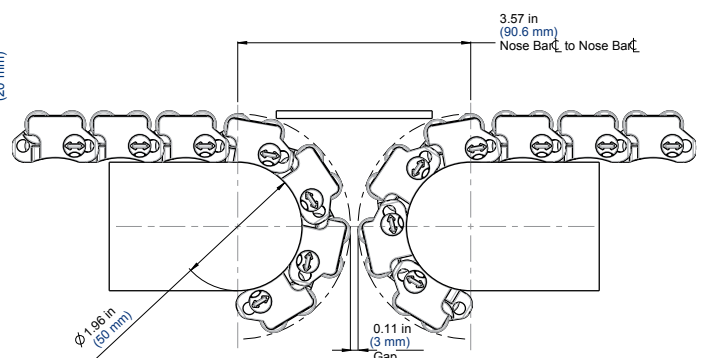

Why Choose Rexnord?

When it comes to providing highly engineered products that improve productivity and efficiency for industrial applications worldwide, Rexnord is the most reliable in the industry. Commitment to customer satisfaction and superior value extend across every business function.

Delivering Lowest Total Cost of Ownership

The highest quality products are designed to help prevent equipment downtime and increase productivity and dependable operation.

Valuable Expertise

An extensive product offering is accompanied by global sales specialists, customer service and maintenance support teams, available anytime.

Solutions to Enhance Ease of Doing Business

Commitment to operational excellence ensures the right products at the right place at the right time.

REXNORD

Rexnord Company Overview

Rexnord is a growth-oriented, multi-platform industrial company with leading market shares and highly trusted brands that serve a diverse array of global end markets.

Process & Motion Control

The Rexnord Process & Motion Control platform designs, manufactures, markets and services specified, highly engineered mechanical components used within complex systems where our customers' reliability requirements and the cost of failure or downtime are extremely high.

Water Management

The Rexnord Water Management platform designs, procures, manufactures and markets products that provide and enhance water quality, safety, flow control and conservation.